

### 技术参数 ( Specifications )

- 适用线规 ( Applicable wires ) : AWG#28~AWG#26  
( 0.08mm<sup>2</sup>~0.13mm<sup>2</sup> )
- Insulation diameter : Ø0.85mm~Ø0.95mm
- 适应基板厚度 ( Applicable PC board thickness ) : 0.8~1.6 mm
- 温度范围 ( Temperature range ) : -25°C~85°C
- 额定电压 ( Voltage rating ) : 50V AC/DC
- 额定电流 ( Current rating ) : 1A(AWG#28); 2A(AWG#26)
- 接触电阻 ( Contact resistance ) : ≤20mΩ
- 绝缘电阻 ( Insulation resistance ) : ≥100MΩ
- 耐压 ( Withstand voltage ) : 500V AC/minute
- 认证 ( Standards ) :  E200881

### 阴连接器 (绝缘位移连接) Receptacle (IDC)

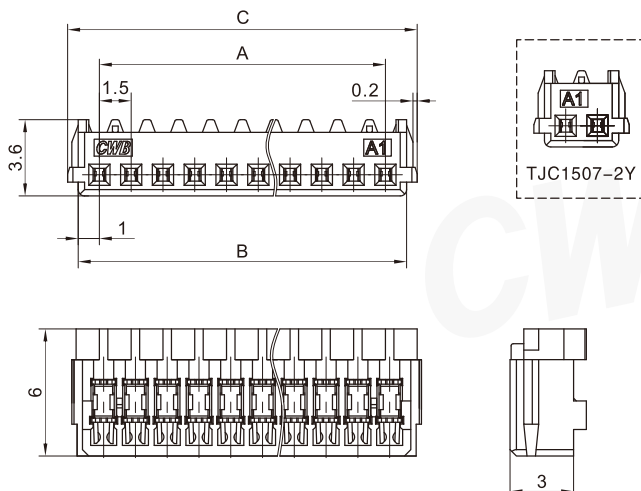

线数 Poles	型号 Type	尺寸Dimensions ( mm )			线数 Poles	型号 Type	尺寸Dimensions ( mm )		
		A	B	C			A	B	C
2	TJC1507-2YI	1.5	3.5	4.5	12	TJC1507-12YI	16.5	18.5	19.5
3	TJC1507-3YI	3.0	5.0	6.0	13	TJC1507-13YI	18.0	20.0	21.0
4	TJC1507-4YI	4.5	6.5	7.5	14	TJC1507-14YI	19.5	21.5	22.5
5	TJC1507-5YI	6.0	8.0	9.0	15	TJC1507-15YI	21.0	23.0	24.0
6	TJC1507-6YI	7.5	9.5	10.5	16	TJC1507-16YI	22.5	24.5	25.5
7	TJC1507-7YI	9.0	11.0	12.0	17	TJC1507-17YI	24.0	26.0	27.0
8	TJC1507-8YI	10.5	12.5	13.5	18	TJC1507-18YI	25.5	27.5	28.5
9	TJC1507-9YI	12.0	14.0	15.0	19	TJC1507-19YI	27.0	29.0	30.0
10	TJC1507-10YI	13.5	15.5	16.5	20	TJC1507-20YI	28.5	30.5	31.5
11	TJC1507-11YI	15.0	17.0	18.0					

材质 · 表面处理 Material and Finish

PA66 UL94V-0; 磷青铜 镀锡 Phos · bronze Tin · Plated

# TJC1507 型条形连接器

## TJC1507 Bar Connector

间距 ( space ) : 1.5mm

### 中继连接器 (面板安装) Relay (Panel mount)

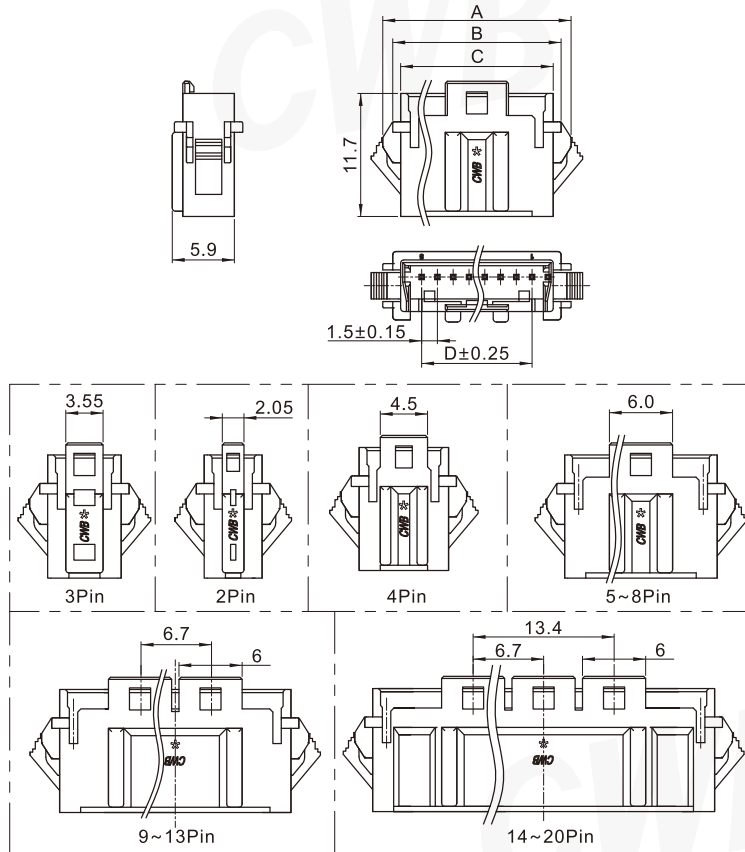

线数 Poles	型号 Type	尺寸 Dimensions ( mm )			
		A	B	C	D
2	TJC1507-2RP	8.9	7	5.5	1.5
3	TJC1507-3RP	10.4	8.5	7	3
4	TJC1507-4RP	11.9	10	8.5	4.5
5	TJC1507-5RP	13.4	11.5	10	6
6	TJC1507-6RP	14.9	13	11.5	7.5
7	TJC1507-7RP	16.4	14.5	13	9
8	TJC1507-8RP	17.9	16	14.5	10.5
9	TJC1507-9RP	19.4	17.5	16	12
10	TJC1507-10RP	20.9	19	17.5	13.5
11	TJC1507-11RP	22.4	20.5	19	15
12	TJC1507-12RP	23.9	22	20.5	16.5
13	TJC1507-13RP	25.4	23.5	22	18
14	TJC1507-14RP	26.9	25	23.5	19.5
15	TJC1507-15RP	28.4	26.5	25	21
16	TJC1507-16RP	29.9	28	26.5	22.5
17	TJC1507-17RP	31.4	29.5	28	24
18	TJC1507-18RP	32.9	31	29.5	25.5
19	TJC1507-19RP	34.4	32.5	31	27
20	TJC1507-20RP	35.9	34	32.5	28.5
材质 · 表面处理 Material and Finish					
PA66 UL94V-0; 磷青铜 镀锡 Phos · bronze Tin · Plated					

# TJC1507 型条形连接器

## TJC1507 Bar Connector

间距 ( space ) :1.5mm

阳连接器 (立式, 直插, 含定位柱, 含小弯) Header (V, DIP, W/Boss, W/Kink)

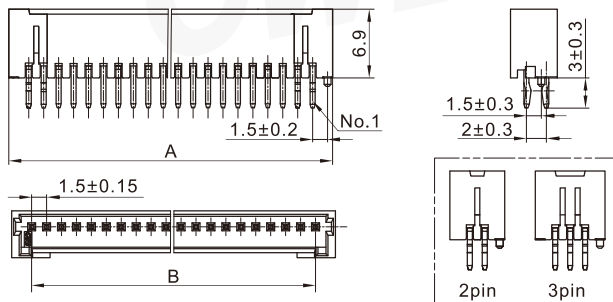

线数 Poles	型号 Type	尺寸Dimensions ( mm )		线数 Poles	型号 Type	尺寸Dimensions ( mm )	
		A	B			A	B
2	TJC1507-2ADK	5.5	1.5	12	TJC1507-12ADK	20.5	16.5
3	TJC1507-3ADK	7	3	13	TJC1507-13ADK	22	18
4	TJC1507-4ADK	8.5	4.5	14	TJC1507-14ADK	23.5	19.5
5	TJC1507-5ADK	10	6	15	TJC1507-15ADK	25	21
6	TJC1507-6ADK	11.5	7.5	16	TJC1507-16ADK	26.5	22.5
7	TJC1507-7ADK	13	9	17	TJC1507-17ADK	28	24
8	TJC1507-8ADK	14.5	10.5	18	TJC1507-18ADK	29.5	25.5
9	TJC1507-9ADK	16	12	19	TJC1507-19ADK	31	27
10	TJC1507-10ADK	17.5	13.5	20	TJC1507-20ADK	32.5	28.5
11	TJC1507-11ADK	19	15				
材质 · 表面处理 Material and Finish							
PA66+GF UL94V-0; 黄铜 镀锡 Brass Tin · Plated							

阳连接器 (卧式, 直插, 带挡板, 含小弯) Header (H, DIP, W/PCB stabilizer, W/Kink)

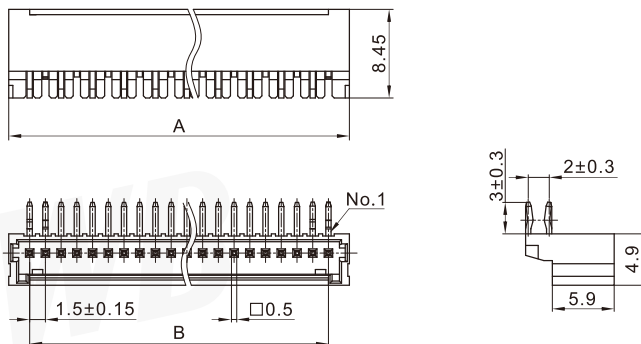

# TJC1507 型条形连接器

## TJC1507 Bar Connector

间距 ( space ) : 1.5mm

线数 Poles	型号 Type	尺寸Dimensions ( mm )		线数 Poles	型号 Type	尺寸Dimensions ( mm )	
		A	B			A	B
2	TJC1507-2AWJK	5.5	1.5	12	TJC1507-12AWJK	20.5	16.5
3	TJC1507-3AWJK	7	3	13	TJC1507-13AWJK	22	18
4	TJC1507-4AWJK	8.5	4.5	14	TJC1507-14AWJK	23.5	19.5
5	TJC1507-5AWJK	10	6	15	TJC1507-15AWJK	25	21
6	TJC1507-6AWJK	11.5	7.5	16	TJC1507-16AWJK	26.5	22.5
7	TJC1507-7AWJK	13	9	17	TJC1507-17AWJK	28	24
8	TJC1507-8AWJK	14.5	10.5	18	TJC1507-18AWJK	29.5	25.5
9	TJC1507-9AWJK	16	12	19	TJC1507-19AWJK	31	27
10	TJC1507-10AWJK	17.5	13.5	20	TJC1507-20AWJK	32.5	28.5
11	TJC1507-11AWJK	19	15				
材质 · 表面处理 Material and Finish							
PA66+GF UL94V-0; 黄铜 镀锡 Brass Tin · Plated							

### 阳连接器 (立式, 表面装贴, 含定位柱) Header (V, SMT, W/Boss)

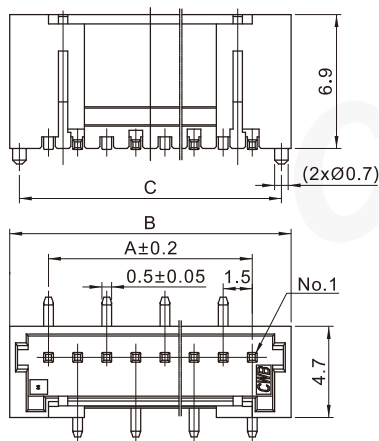

线数 Poles	型号 Type	尺寸Dimensions ( mm )			线数 Poles	型号 Type	尺寸Dimensions ( mm )		
		A	B	C			A	B	C
2	TJC1507-2ABD	1.5	5.5	4.5	12	TJC1507-12ABD	16.5	20.5	19.5
3	TJC1507-3ABD	3	7	6	13	TJC1507-13ABD	18	22	21
4	TJC1507-4ABD	4.5	8.5	7.5	14	TJC1507-14ABD	19.5	23.5	22.5
5	TJC1507-5ABD	6	10	9	15	TJC1507-15ABD	21	25	24
6	TJC1507-6ABD	7.5	11.5	10.5	16	TJC1507-16ABD	22.5	26.5	25.5
7	TJC1507-7ABD	9	13	12	17	TJC1507-17ABD	24	28	27
8	TJC1507-8ABD	10.5	14.5	13.5	18	TJC1507-18ABD	25.5	29.5	28.5
9	TJC1507-9ABD	12	16	15	19	TJC1507-19ABD	27	31	30
10	TJC1507-10ABD	13.5	17.5	16.5	20	TJC1507-20ABD	28.5	32.5	31.5
11	TJC1507-11ABD	15	19	18					
材质 · 表面处理 Material and Finish									
PA UL94V-0; 黄铜 镀锡 Brass Tin · Plated									

# TJC1507 型条形连接器

## TJC1507 Bar Connector

间距 ( space ) :1.5mm

### 阳连接器 (立式, 表面装贴, 带吸嘴盖) Header (V, SMT, With cover)

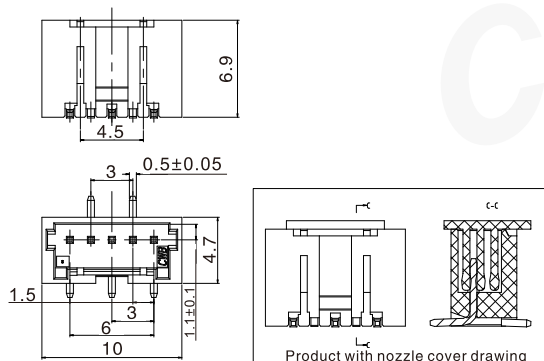

线数 Poles	型号 Type
5	TJC1507-5ABX
材质 · 表面处理 Material and Finish	
PA UL94V-0; 黄铜 镀锡 Brass Tin · Plated	

### 阳连接器 (立式, 表面装贴, 含定位柱) Header (V, SMT, W/Boss)

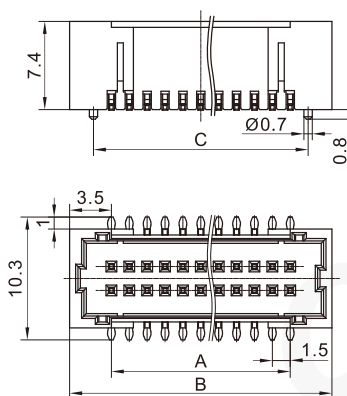

线数 Poles	型号 Type	尺寸Dimensions (mm)			线数 Poles	型号 Type	尺寸Dimensions (mm)		
		A	B	C			A	B	C
22	TJC1507-2x11ABD	15	22	18	32	TJC1507-2x16ABD	22.5	29.5	25.5
24	TJC1507-2x12ABD	16.5	23.5	19.5	34	TJC1507-2x17ABD	24	31	27
26	TJC1507-2x13ABD	18	25	21	36	TJC1507-2x18ABD	25.5	32.5	28.5
28	TJC1507-2x14ABD	19.5	26.5	22.5	38	TJC1507-2x19ABD	27	34	30
30	TJC1507-2x15ABD	21	28	24	40	TJC1507-2x20ABD	28.5	35.5	31.5
材质 · 表面处理 Material and Finish									
PA UL94V-0; 黄铜 镀锡 Brass Tin · Plated									

### 安装尺寸 Mounting Measurement

TJC1507-nRP

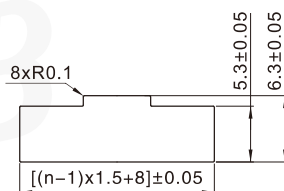

Panel Board

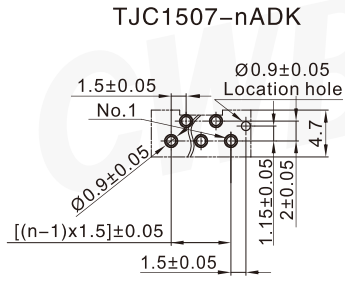

PCB Layout

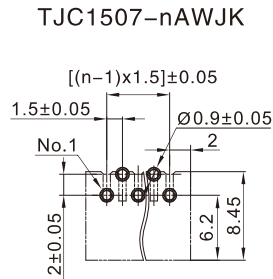

PCB Layout

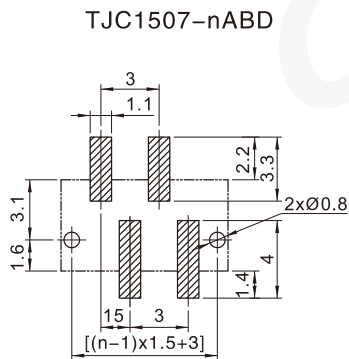

PCB Layout

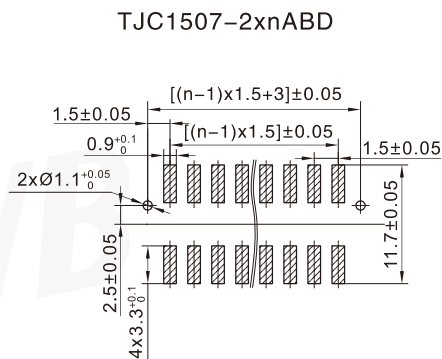

PCB Layout