

### 技术参数 ( Specifications )

适用线规 ( Applicable wires ) : AWG#28~AWG#22  
 适应基板厚度 ( Applicable PC board thickness ) : 1.6 mm  
 温度范围 ( Temperature range ) : -25℃~85℃  
 额定电压 ( Voltage rating ) : 250V AC/DC  
 额定电流 ( Current rating ) : 3A  
 接触电阻 ( Contact resistance ) : ≤ 10mΩ  
 绝缘电阻 ( Insulation resistance ) : ≥ 1000MΩ  
 耐压 ( Withstand voltage ) : 1000V AC/minute

认证 ( Standards ) :  E200881

### 插簧 Contact

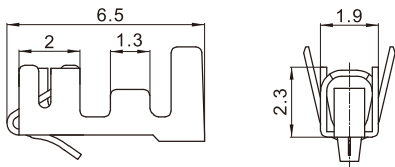

型号 Type	适用导线范围 Wire Range		导线外径 Wire ins.Dis	备注 Remark
	mm <sup>2</sup>	AWG#		
CH-TJC3	0.22 ~ 0.33	24 ~ 22	1.4 ~ 1.6	料带宽度3.0mm
CH-TJC3B	0.22 ~ 0.33	24 ~ 22	1.4 ~ 1.6	料带宽度2.5mm
CH-TJC3-1	0.13	26	1.3	料带宽度3.0mm
CH-TJC3-2	0.08	28	1.2	料带宽度3.0mm
材质 · 表面处理 Material and Finish				
磷青铜 镀锡 Phos · bronze Tin · Plated				

### 孔座 Housing

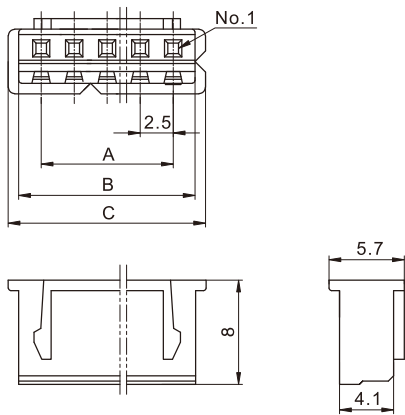

线数 Poles	型号 Type	尺寸 Dimensions(mm)			线数 Poles	型号 Type	尺寸 Dimensions(mm)		
		A	B	C			A	B	C
2	TJC3-2Y	2.5	5.8	7.4	9	TJC3-9Y	22.5	25.8	27.4
3	TJC3-3Y	5.0	8.3	9.9	10	TJC3-10Y	25.0	28.3	29.9
4	TJC3-4Y	7.5	10.8	12.4	11	TJC3-11Y	27.5	30.8	32.4
5	TJC3-5Y	10.0	13.3	14.9	12	TJC3-12Y	30.0	33.3	34.9
6	TJC3-6Y	12.5	15.8	17.4	13	TJC3-13Y	32.5	35.8	37.4
7	TJC3-7Y	15.0	18.3	19.9	14	TJC3-14Y	35.0	38.3	39.9
8	TJC3-8Y	17.5	20.8	22.4	15	TJC3-15Y	37.5	40.8	42.4
材质 Material		PA66 UL94V-0							

### 阳连接器 (立式, 直插, 含小弯) Header (V, DIP, W/Kink)

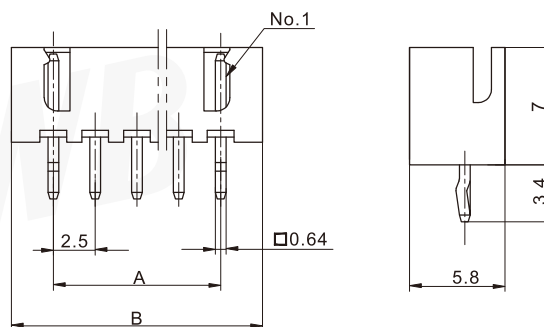

阳连接器 (卧式, 直插) Header (H, DIP)

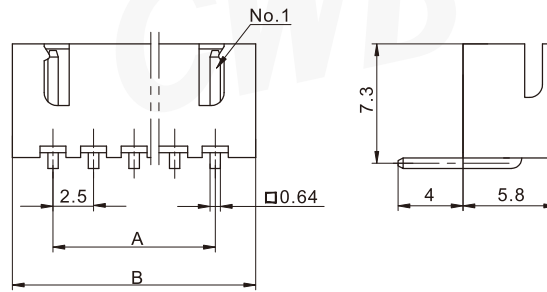

阳连接器 (立式, 直插, 含定位柱, 含小弯) Header (V, DIP, W/Boss, W/Kink)

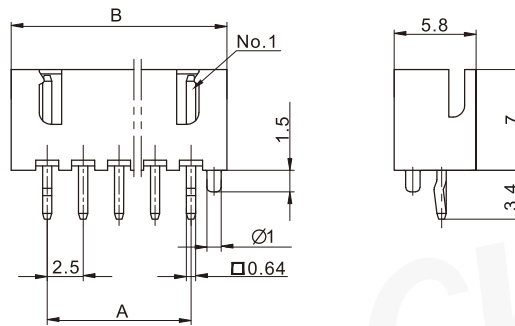

阳连接器 (卧式, 直插, 带挡板, 含小弯) Header (H, DIP, W/PCB stabilizer, W/Kink)

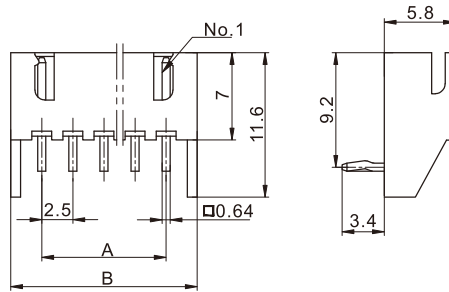

阳连接器 (立式, 直插, 带挡板) Header (V, DIP, W/PCB stabilizer)

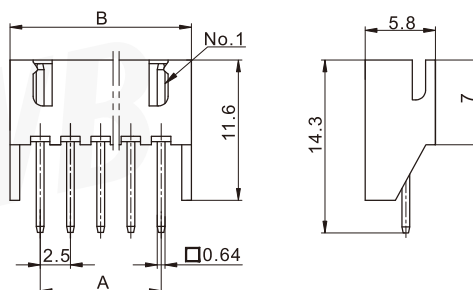

# TJC3 型条形连接器

## TJC3 Bar Connector

间距 ( space ) :2.5mm

线数 Poles	型号 Type					尺寸 Dimensions(mm)	
	(V, DIP, W/Kink)	(H, DIP)	(V, DIP, W/Boss, W/Kink)	(H, DIP, W/PCB stabilizer, W/Kink)	(V, DIP, W/PCB stabilizer)	A	B
2	TJC3-2AK	TJC3-2AW	TJC3-2ADK	TJC3-2AWJK	TJC3-2AJ	2.5	7.5
3	TJC3-3AK	TJC3-3AW	TJC3-3ADK	TJC3-3AWJK	TJC3-3AJ	5	10
4	TJC3-4AK	TJC3-4AW	TJC3-4ADK	TJC3-4AWJK	TJC3-4AJ	7.5	12.5
5	TJC3-5AK	TJC3-5AW	TJC3-5ADK	TJC3-5AWJK	TJC3-5AJ	10	15
6	TJC3-6AK	TJC3-6AW	TJC3-6ADK	TJC3-6AWJK	TJC3-6AJ	12.5	17.5
7	TJC3-7AK	TJC3-7AW	TJC3-7ADK	TJC3-7AWJK	TJC3-7AJ	15	20
8	TJC3-8AK	TJC3-8AW	TJC3-8ADK	TJC3-8AWJK	TJC3-8AJ	17.5	22.5
9	TJC3-9AK	TJC3-9AW	TJC3-9ADK	TJC3-9AWJK	TJC3-9AJ	20	25
10	TJC3-10AK	TJC3-10AW	TJC3-10ADK	TJC3-10AWJK	TJC3-10AJ	22.5	27.5
11	TJC3-11AK	TJC3-11AW	TJC3-11ADK	TJC3-11AWJK	TJC3-11AJ	25	30
12	TJC3-12AK	TJC3-12AW	TJC3-12ADK	TJC3-12AWJK	TJC3-12AJ	27.5	32.5
13	TJC3-13AK	TJC3-13AW	TJC3-13ADK	TJC3-13AWJK	TJC3-13AJ	30	35
14	TJC3-14AK	TJC3-14AW	TJC3-14ADK	TJC3-14AWJK	TJC3-14AJ	32.5	37.5
15	TJC3-15AK	TJC3-15AW	TJC3-15ADK	TJC3-15AWJK	TJC3-15AJ	35	40
16	TJC3-16AK	TJC3-16AW	TJC3-16ADK	TJC3-16AWJK	TJC3-16AJ	37.5	42.5
材质 · 表面处理 Material and Finish							
PA66 UL94V-0; 黄铜 镀锡 Brass Tin · Plated							

### 阳连接器 (立式, 直插, 含小弯, 含定位柱, 带锁扣) Header (V, DIP, W/Kink, W/Boss, W/Lock)

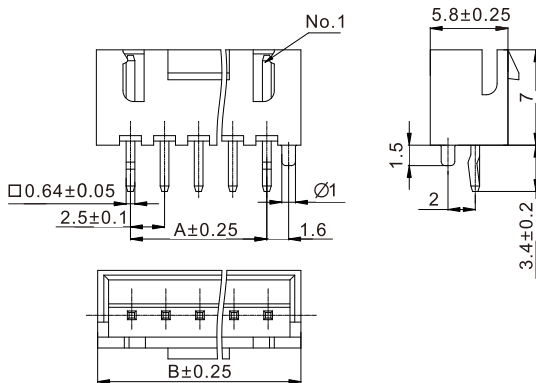

线数 Poles	型号 Type	尺寸 Dimensions ( mm )	
		A	B
3	TJC3-3ADK-1	5	10
5	TJC3-5ADK-1	10	15
6	TJC3-6ADK-1	12.5	17.5
12	TJC3-12ADK-1	27.5	32.5
13	TJC3-13ADK-1	30	35
材质 · 表面处理 Material and Finish			
PA66 UL94V-0; 黄铜 镀锡 Brass Tin · Plated			

### 阳连接器 (立式, 直插, 含小弯) Header (V, DIP, W/Kink)

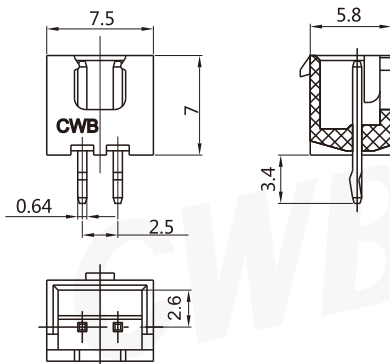

型号 Type	材质 · 表面处理 Material and Finish
TJC3-2AK-1	PA66 UL94V-0; 黄铜 镀锡 Brass Tin · Plated

# TJC3 型条形连接器 TJC3 Bar Connector

间距 (space) :2.5mm

## 阳连接器 (立式, 直插, 含小弯) Header (V, DIP, W/Kink)

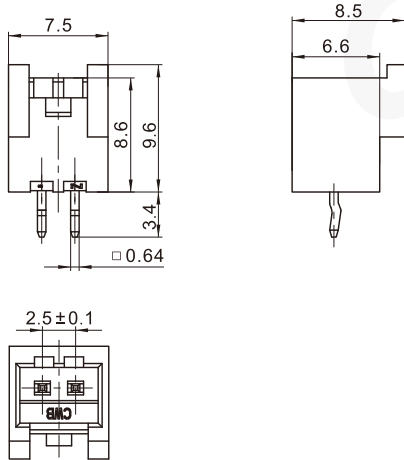

型号 Type	材质 · 表面处理 Material and Finish
TJC3B-2AK	PA66 UL94V-0; 黄铜 镀锡 Brass Tin · Plated

## 阳连接器 (立式, 直插, 含定位柱, 含小弯) Header (V, DIP, W/Boss, W/Kink)

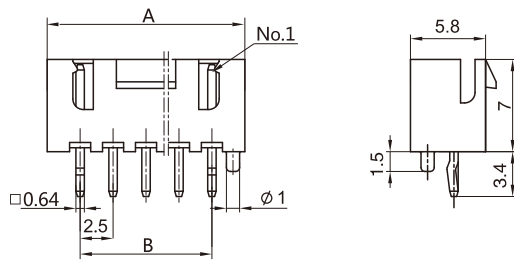

线数 Poles	型号 Type	尺寸 Dimensions (mm)	
		A	B
3	TJC3B-3AK	5.0	10.0
4	TJC3B-4AK	7.5	12.5
5	TJC3B-5AK	10.0	15.0
6	TJC3B-6AK	12.5	17.5
7	TJC3B-7AK	15.0	20.0
8	TJC3B-8AK	17.5	22.5
9	TJC3B-9AK	20.0	25.0
10	TJC3B-10AK	22.5	27.5
11	TJC3B-11AK	25.0	30.0
12	TJC3B-12AK	27.5	32.5
13	TJC3B-13AK	30.0	35.0
14	TJC3B-14AK	32.5	37.5
15	TJC3B-15AK	35.0	40.0
16	TJC3B-16AK	37.5	42.5
材质 · 表面处理 Material and Finish			
PA66 UL94V-0; 黄铜 镀锡 Brass Tin · Plated			

## 阳连接器 (立式, 表面装贴, 带吸嘴盖) Header (V, SMT, With cover)

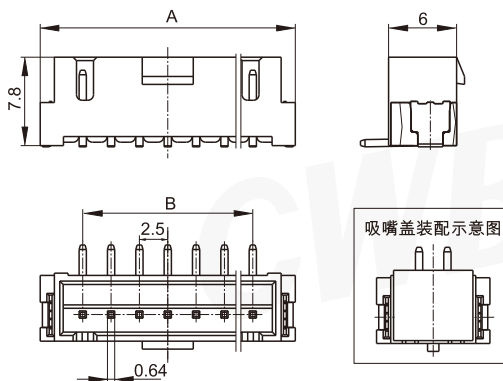

线数 Poles	型号 Type	尺寸 Dimensions (mm)		线数 Poles	型号 Type	尺寸 Dimensions (mm)	
		A	B			A	B
2	TJC3-2ABX	10.0	2.5	10	TJC3-10ABX	30.0	22.5
3	TJC3-3ABX	12.5	5.0	11	TJC3-11ABX	32.5	25.0
4	TJC3-4ABX	15.0	7.5	12	TJC3-12ABX	35.0	27.5
5	TJC3-5ABX	17.5	10.0	13	TJC3-13ABX	37.5	30.0
6	TJC3-6ABX	20.0	12.5	14	TJC3-14ABX	40.0	32.5
7	TJC3-7ABX	22.5	15.0	15	TJC3-15ABX	42.5	35.0
8	TJC3-8ABX	25.0	17.5	16	TJC3-16ABX	45.0	37.5
9	TJC3-9ABX	27.5	20.0				
材质 · 表面处理 Material and Finish							
PA UL94V-0; 黄铜 镀锡 Brass Tin · Plated							

阳连接器 (卧式, 表面装贴) Header (H, SMT)

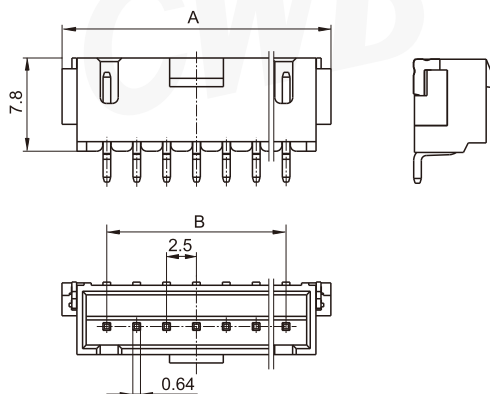

线数 Poles	型号 Type	尺寸 Dimensions ( mm )		线数 Poles	型号 Type	尺寸 Dimensions ( mm )	
		A	B			A	B
2	TJC3-2AWB	10.0	2.5	10	TJC3-10AWB	30.0	22.5
3	TJC3-3AWB	12.5	5.0	11	TJC3-11AWB	32.5	25.0
4	TJC3-4AWB	15.0	7.5	12	TJC3-12AWB	35.0	27.5
5	TJC3-5AWB	17.5	10.0	13	TJC3-13AWB	37.5	30.0
6	TJC3-6AWB	20.0	12.5	14	TJC3-14AWB	40.0	32.5
7	TJC3-7AWB	22.5	15.0	15	TJC3-15AWB	42.5	35.0
8	TJC3-8AWB	25.0	17.5	16	TJC3-16AWB	45.0	37.5
9	TJC3-9AWB	27.5	20.0				

材质 · 表面处理 Material and Finish  
PA UL94V-0; 黄铜 镀锡 Brass Tin · Plated

安装尺寸 Mounting Measurement

TJC3-nAK, TJC3-nAW, TJC3-nAWJ, TJC3-nAJ, TJC3B-nAK, TJC3-nAK-1

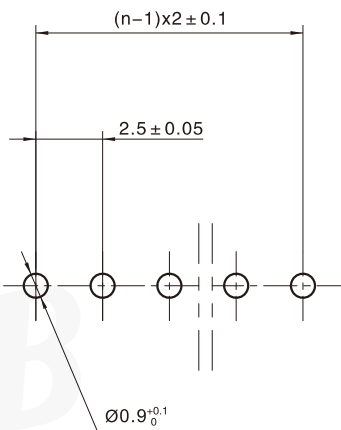

PCB Layout

TJC3-nADK

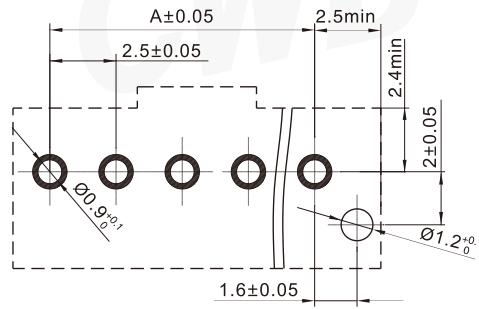

PCB Layout

TJC3-nAB

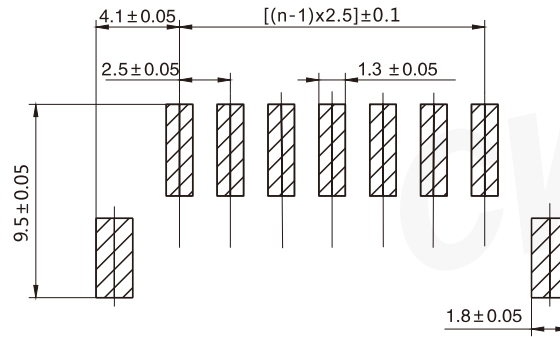

PCB Layout

TJC3-nAWB

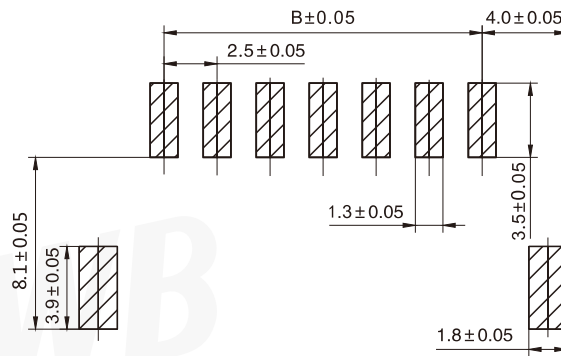

PCB Layout